

Proposal of Balloon Type Drone for Overhead Shooting in Remote Joint Classroom

Ryo OKAMOTO, Yasuo MIYOSHI & Yuichiro MORI
Faculty of Science and Technology, Kochi University, Japan
{ryooka, miyoshi, ymori}@is.kochi-u.ac.jp

Abstract: In Japan, the population decreases especially in the mountainous area due to the declining birthrate, and it is difficult to maintain the public high schools in Kochi Prefecture. Kochi Prefecture Board of Education has introduced trial remote joint classes three years ago. However, as a result of the trial operation, problems on student's shooting method in distance classroom were clarified. Therefore, we examined the shooting method in the distance classroom and designed and developed a new shooting device for the remote classroom. In this paper, we describe the proposal and development of "Balloon Type Drone" for supporting student photography in a remote joint classroom.

Keywords: drone, photographing device, remote joint class, remote classroom

1. Introduction

In recent years, declining birthrate and aging is highly increasing in Japan, and also in Kochi Prefecture where our university is located, depopulation is extremely remarkable. Thus, in the public high schools, it is difficult to manage due to extremely marked depopulation, but the board of education decided to continue schools if it is more than 20 students in one class at one grade. It is predicted that 13 schools of 36 are correspond to the case (Kochi Prefecture School Board, 2018). For the problem, the board of education started to introduce remote joint class support system which based on "video-conferencing technology" from three years ago, and the authors have been provided technical cooperation. Through the test installation of the remote joint class system, we found some problems which are caused by the number and the functional limitations of a "photographing device" as video camera included in the system. Therefore, we propose the new approach aiming to provide flexibility of shooting students in a remote classroom and intelligent support functions for a teacher in distance classroom. In this paper, we describe the design and the prototype of "Balloon Type Drone" as a photographing device in remote classroom.

2. Problems of Introduced Remote Joint Classroom Support System

Through multiple inspections of the remote joint classes and the discussions with all the parties concerned, we have listed problems to improve the system that are earned from the test installation. As a result, some of the problems are concerned with the configuration and the functions of the photographing devices. There are two sides of classroom for the remote joint class, "transmitting side" and "receiving side". In the receiving side, there are two photographing devices. The one is the fixed video camera which is located in front of students, and the other is handy camera for the support teacher. We have focused on the problems with relation to current photographing method.

There are problems for each camera, the fixed camera and the handy camera, in the remote classroom. The fixed camera is mainly used to shoot the students from front of them with a function of angle adjustment via control box. This is a quite typical and a necessary equipment for distance classroom, but angle control function of the camera is rarely used in actually because of it's too much of a bother. If additional fixed cameras are equipped in the classroom, it is helpful for the lecturing teacher to know more details of student's status, but it cannot be affordable in cost under existing our circumstances. On the other hand, the use of handy camera was out of the question. Unfortunately, the camera has never used within our inspections.

The students in the remote classroom, they sit by side by 2 to 3 and 3 to 4 in row to fit in the angle of view of the camera. The lecturing teacher in the transmitting side wants watch the status of the student behind the second row. But, it is impossible in principle even if the teacher adjusts the angle of the camera, the angle of view of the fixed camera is positionally limited, so the teacher cannot observe the work at students' hand. To compliment the situation, the support teacher, who is not special in the subject, goes around the students. However, there is no way of communication between the lecturing teacher and the support teacher besides a briefing after the class.

3. Proposal of “Balloon Type Drone”

We aimed to realize an ideal photographing method in the remote classroom. There are many studies on shooting techniques in distance classes (Wang, R et al., 2016; N. Osawa & K. Asai, 2005; Y. Ochi and Y. Takeda, 2013), but few attempts are made to enable shooting in a movable and bird's-eye view. Our approach is to challenge “yet another photographing device” which can be located freely to where a teacher wants and is possible to shoot students even from above as cheap as possible. And further, it is desirable that the functions of traversal and shooting functions are intellectually controlled without taking time and effort of a teacher. We propose a “Balloon Type Drone” using in the classroom. In this research, we aim to develop the drone which is located near the ceiling by obtaining buoyancy by a balloon filled with helium gas and which can autonomously move as necessary. The balloon type drone that we aim for has the following advantages.

- (1) Safety: Even when the function stops due to a failure of a motor or the like, there is no danger of falling and it only stays on the ceiling.
- (2) Quietness: Because it uses the buoyancy of helium gas, it is not necessary to rotate the motor all the time like a general drone, so that quietness can be expected.
- (3) Economy: It is possible to reduce the money cost by developing by utilizing an inexpensive commercial small device.
- (4) Functionality: It is highly possible to realize advanced educational support functions using sensors or image recognition etc. by technical development using small devices.

4. Development of “Balloon Type Drone”

First of all, we designed and prototyped a photographing control module as shown in Figure 1. In the module, the two DC motors are arranged coaxially so as to cancel the counter torque. The motor located at the top is used for detachment from the ceiling. The motor arranged in the lower part allows horizontal movement and direction change by the “Rotating Duct” connected to the stepping motor.

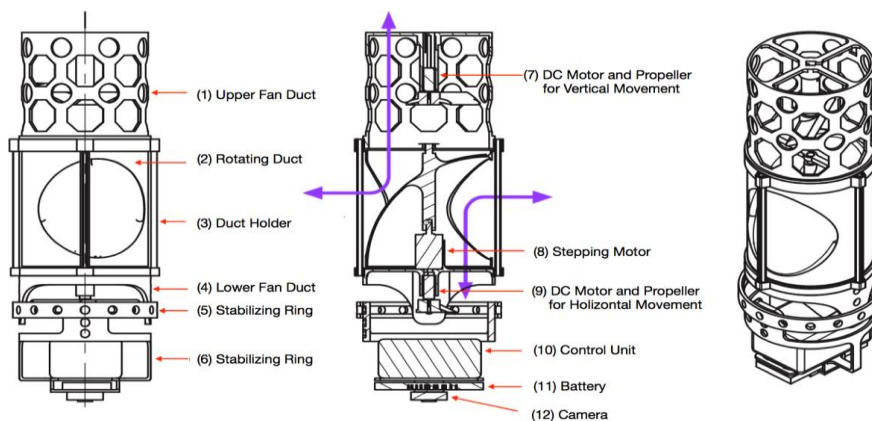

Figure1. Design of “Photographing Control Module”



Figure 2. Prototype of “Balloon Type Drone”

The control unit uses Raspberry Pi Zero W, to which motor drivers, LiPo batteries and a camera are connected in lower part. The enclosure and propeller of this module are designed using 3D-CAD and 3D printers from scratch, and the whole weight of the module is 127g including batteries.

We created the balloon body shown in Figure 2 to mount the photographing control module. The balloon used a polyester aluminum vapor deposited film with a thickness of 28 micron, its size was 30 cm x 90 cm x 90 cm, and the loaded weight was around 160g.

We carried out a flight test of the drone. The drones floated to the ceiling and confirmed that descending and change of direction can be done without problems by the propellers. The control program has been created using Python, and at the moment it is currently only executing the script stored in Raspberry Pi by logging in remotely from the notebook PC. The noise generated by the rotation of propellers was quite small if the rotation speed was suppressed. Considering that it is not always turning the propeller, it can be judged that it is a practical range. In addition, it was confirmed that the photographing function by the camera also operates without problems.

5. Conclusions

In this paper, we proposed a balloon type drone and described about its design and development of the prototype, in order to solve problems related to photographing in remote joint classroom. We will continue to work on improving enclosure and propeller etc. to improve quietness and efficiently obtain propulsion. As future tasks, we will study “autonomous movement control program” to realize accurate movement and study information acquisition by image analysis to realize educational support functions using them. The balloon type drones introduced in this paper have already been patented.

Acknowledgements

This research is supported in part by Grant-in-Aid for JSPS JP17K01131 from Ministry of Education, Culture, Sports, Science and Technology of Japan.

References

- Kochi Prefecture School Board (2018). Efforts for Distance Education (Project entrusted by MEXT). <http://www.pref.kochi.lg.jp/soshiki/311701/2016060600102.html>.
- Wang, R., Dong, Tony X. Han and Lei Mei (2016), Robust tracking via monocular active vision for an intelligent teaching system, *The Visual Computer, Volume 32*, Issue 11, pp.1379-1394.
- N. Osawa and K. Asai (2005). Distributed automatic camera control system tracking markers for distance education, *ITRE 2005*, pp. 377-381.
- Y. Ochi and Y. Takeda (2013). Development of a Camera Control System Using Human Gestures Recognition, *IMECS 2013, Vol I*, ISBN: 978-988-19251-8-3.